

## Reduction of Harmonics & Improve Efficiency Using Multi Pulse Converter

Hemant Dhanuk<sup>1</sup>, Prashant Singh<sup>2</sup>, Saurabh Gupta<sup>3</sup>

Department of Electrical and Electronics Engineering

Technocrats Institute of Technology & Science, Bhopal

dhanukhemant12@gmail.com<sup>1</sup>, prashantmits@gamil.com<sup>2</sup>, saurabhgupta.sgsits@gmail.com<sup>3</sup>

**Abstract:** Due to switching of power electronics devices harmonic are induced in the line. These harmonic induced bad effect on transmission line such as dipping of voltage, it also minimized the efficiency and life of equipments. In this study presents line commutated controlled multipulse converters for solving the harmonic problem. The effect of increasing the number of pulses on the performance of AC to DC converters has been analyzed. For performance comparison major factors considered are the ripple percentage, form factor and the total harmonic distortion (THD). The effects of load variation on multi-pulse AC to DC converters have also been investigated. This work presented the comparative study of 24, 36, 48 and 60 pulse converters.

**Keywords** *Multipulse converter, Harmonics distortion, Ripple counters.*

### 1. Introduction

Three-phase controlled rectifiers have a wide range of applications, to large high voltage direct current (HVDC) transmission systems from small rectifiers.

They are used for electrochemical processes, wide range of motor drives, controlled power supplies, traction equipment and other applications. The commutation process can be classified into two important categories namely: Line-commutated controlled rectifiers and Force-commutated pulse width modulated rectifiers. There are several techniques primarily adopted for the mitigation of harmonics in a 3-phase converter and multi-pulse converters fall in the same category of remedial measures. Multi pulse converters are the most fundamental solution for harmonic problem in a three-phase converter system. With the advancements in technology advances these converters and other power electronic devices with integrated magnetic featuring high input power quality and better performance would be required by many industrial, commercial applications, power supplies. The effect of increasing the number of pulses of AC to DC converters directly alters its performance parameters like ripple percentage, form factor and the total harmonic distortion.

Multipulse converters are converters providing more than six pulses of DC voltage per cycle from AC input or the converter having more steps in AC input current than that of six pulse bridge rectifier supply current. Phase shifting transformers are used to derive multipulse phase supply from three-phase AC mains using different combinations of transformer windings such as star, delta, zigzag, polygon, fork etc. In this thesis we use zigzag transformer. The phase-shifting transformers play a key role in the multi-pulse rectifier's performance. Jiaopu et.al [1] discussed commonly used basic connections of phase-shifting transformer, such as Scott, polygon, star/delta, extended-delta and zigzag and gave the analyses and comparisons between them. Focusing on 12-pulse phase-shifting transformers, the research highlighted possible strategies from basic connections to 12-pulse phase-shifting transformers which illustrate the evolution and its basic principles which may be extended to higher pulse converters. Singh et.al [3] analyzed the performance of multi-pulse electronic load controller for isolated asynchronous generator, as load controller conventional electronic based six pulse uncontrolled rectifier contains large content of harmonics. A comparative study of three phase controlled multi pulse converters was presented by [4] for biomass, gas turbine, wind system based power plant, diesel, hydro, , and incorporated input current shaping of controlled rectifier using multi-pulse current shaping concept. The author Xigeng et.al [6] introduced the realization of phase-shifting of the multi-pulse converter transformer and the

method for calculating stretch phase-shifting angle, triangle voltage and the 7 number of windings and analyzed the simulation for the 30-pulse rectification system based on this transformer. Arvindan et.al [7] proposed two 24-pulse rectifier topologies based on phase shifting using conventional magnetic over PSCAD environment.

## 2. Controlled Rectifiers

There are two types of conversion techniques , one is uncontrolled in which diodes are implemented and other is controlled in which thyristors are implemented respectively [8].The performance improvement is achieved for total harmonics distortion (THD) in input current, DC voltage ripples and form factor. Three-phase controlled rectifiers have a wide range of applications, to large high voltage direct current (HVDC) transmission systems from small rectifiers. They are used for electrochemical processes, wide range of motor drives, controlled power supplies, traction equipment and other applications.

### 2.1 Three-phase Half-wave Rectifier

To control the load voltage, the half-wave rectifier uses three common-cathode thyristor arrangements. The thyristor will conduct (ON state), when the anode-to-cathode voltage  $V_{AK}$  is positive and a firing current pulse  $I_G$  is applied to the gate terminal. An angle  $\alpha$  controls the load voltage by delaying the firing pulse.

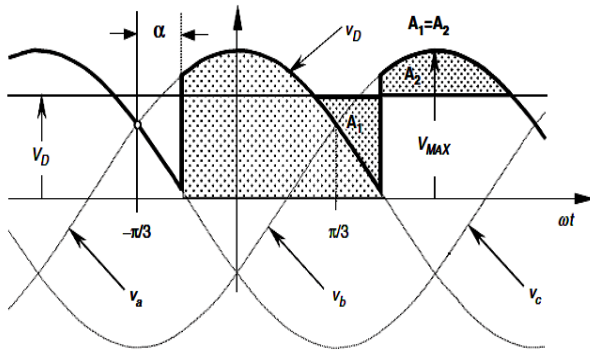

Fig 1: Instantaneous DC voltage  $V_D$ , firing angle  $\alpha$  and average dc voltage  $V_D$  of half wave rectifiers.

The thyristor goes to the non-conducting condition (OFF state) when the following thyristor is switched ON, the current reached a negative value.

$$V_D = \frac{V_{MAX}}{2/3\pi} \int_{-\pi/3+\alpha}^{\pi/3+\alpha} \cos\omega t. d(\omega t)$$

## 2.2 Six-pulse or Double Star Rectifier

The thyristor side windings of the transformer shown in Figure 2 form a six-phase system, resulting in a six-pulse star point (midpoint connection). Disregarding commutation overlap, each valve conducts only during  $60^\circ$  per period.

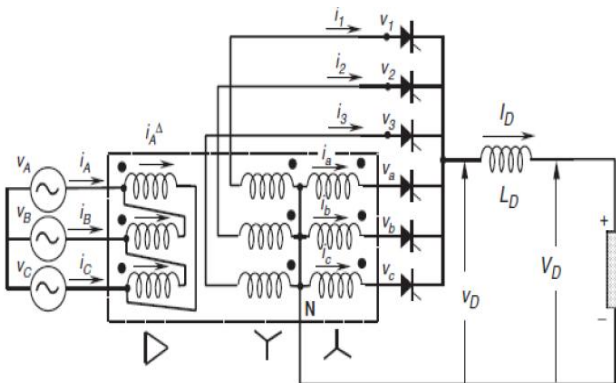

Fig 2: Six-pulse rectifier

## 2.3 Three-phase Full-wave Rectifier

$$V_D = \frac{V_{MAX}}{\pi/3} \int_{-\pi/3+\alpha}^{\pi/3+\alpha} \cos\omega t. d(\omega t)$$

Parallel connection via inter phase transformers permits the implementation of rectifiers for high current applications. For high voltage series connection is also possible, as shown in the full-wave rectifier of Fig.3. With this arrangement, it can be seen that the three common cathode valves generate a positive voltage with respect to the neutral, and a negative voltage is produced by the three common anode valves.

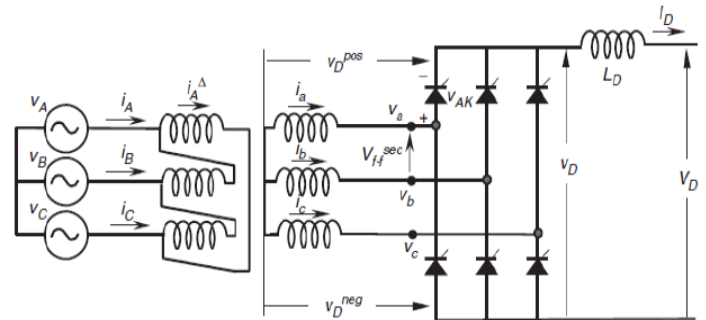

Fig 3: Three-phase full-wave rectifier

$$V_D = \frac{2V_{MAX}}{2\pi/3} \int_{-\pi/3+\alpha}^{\pi/3+\alpha} \cos\omega t. d(\omega t)$$

## 2.4 Harmonic Distortion

The currents of the line-commutated rectifiers are far from being sinusoidal. For example, the currents generated from the 3 phase full wave rectifier have the following harmonic content.

$$i_A = \frac{2\sqrt{3}}{\pi} (\cos\omega t - \frac{1}{5}\cos 5\omega t + \frac{1}{7}\cos 7\omega t - \dots)$$

Some of the characteristics of the currents, obtained from above equation include: the absence of triple

harmonics; the presence of harmonics of order  $6k \pm 1$  for integer values of  $k$ ; those harmonics of orders  $6k+1$  are of positive sequence; those of orders  $6k - 1$  are of negative sequence; the RMS magnitude of the fundamental frequency is,  $i_1 = \sqrt{6}/\pi I_D$  and the RMS magnitude of the  $n$ th harmonic is  $I_n = i_1/n$ .

### 3. Formulation of Pulse converters

The 12-pulse rectifier was obtained with a  $30^\circ$  phase shift between the two secondary transformers. The basis for increasing pulse configurations is provided by the parallel transformers. For instance, the operation of 24 pulses is achieved by means of four transformers with  $15^\circ$  phase shift, and 48-pulse operation requires eight transformers with  $7.5^\circ$  phase shift.

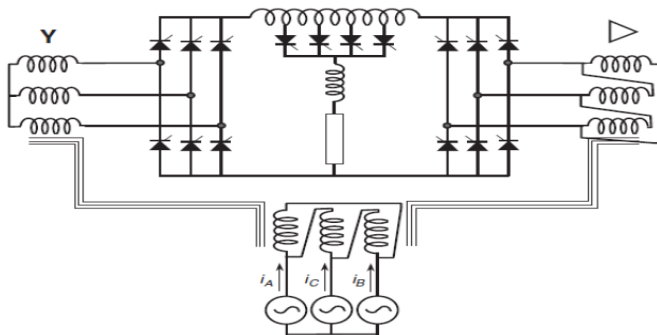

Fig 4: DC ripple reinjection technique of pulse operation

An ingenious and very simple way to reach high pulse operation is shown in Figure 4. This configuration is called dc ripple reinjection. It consists of two parallel converters connected to the load through a multistep reactor. The reactor uses a

chain of thyristor-controlled taps, which are connected to symmetrical points of the reactor. The thyristors located at the reactor are fired at the right time; high-pulse operation is reached. The pulse level operation depends on the number of thyristors connected to the reactor. The basic level of operation is multiplied to the two converters.

### 3.1 HVDC Power Transmission

The use of HVDC systems for interconnections of asynchronous systems is an interesting application. Some continental electric power systems consist of asynchronous networks such as those for the Texas, Quebec networks in North America, and islands loads such as that for the Island of Gotland in the Baltic Sea make good use of the HVDC interconnections.

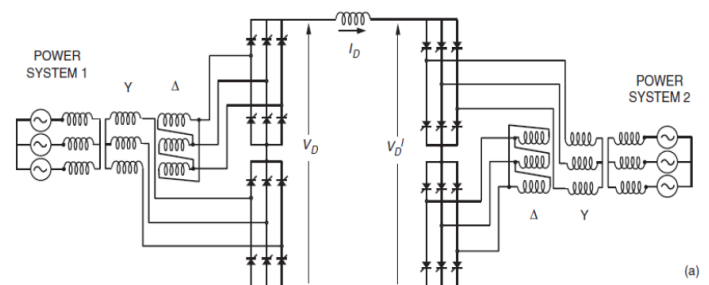

Fig 5: Typical HVDC circuit system

### 4. Simulation Model of Pulse Converters

The present ac–dc converters are cost-effective for universal line and commercial voltage applications but are unreliable and fault prone for higher power applications. Thus, to lighten these problems, multi stage and multi pulse converters have been developed with the flexibility to compliment with

custom power switching modes. For high and ultra high voltage levels the soft switching multi pulse converters offers attractive merits because the component count suffices with the cost of the system.

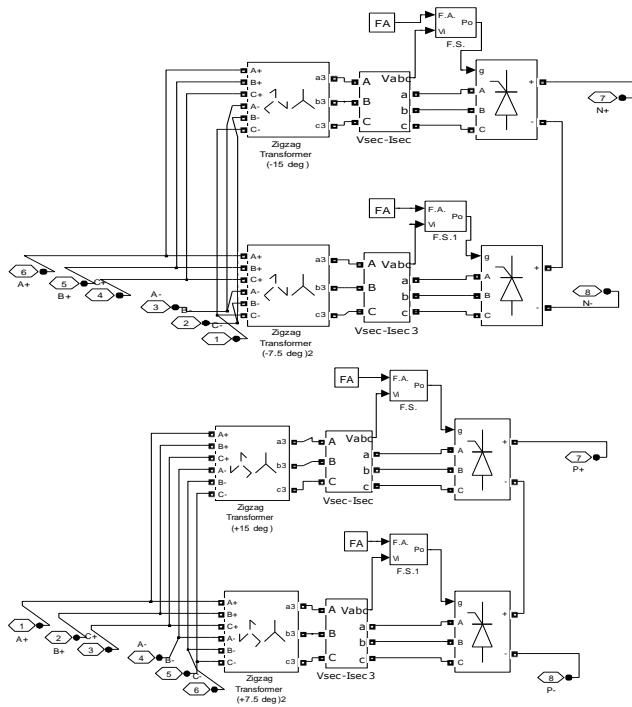

Fig. 6 Twenty Four pulse controlled converters with resistive load

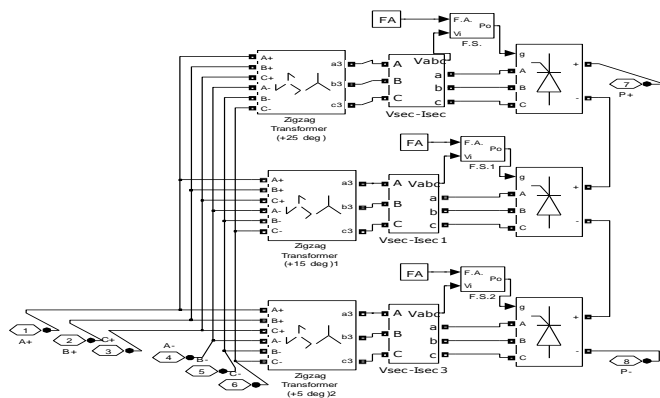

Fig. 7 Thirty six pulse controlled converters with resistive load

#### 4.1 Twenty Four-Pulse Converter

The below Figure 8 A which is shown below is having a twenty four pulse thyristorized converter circuits. Along with two universal bridges in each group at input side the converter requires 4 star-zigzag transformers, two on each positive phase group and negative phase group.

#### 4.4 Thirty Six-Pulse Converter

The simulation model for thirty six pulse thyristorized converter circuit is shown in Figure 9. The converter requires 6 star-zigzag transformers at input side of the converter, 3 in positive phase group and 3 in negative phase group along with three universal bridges in each group

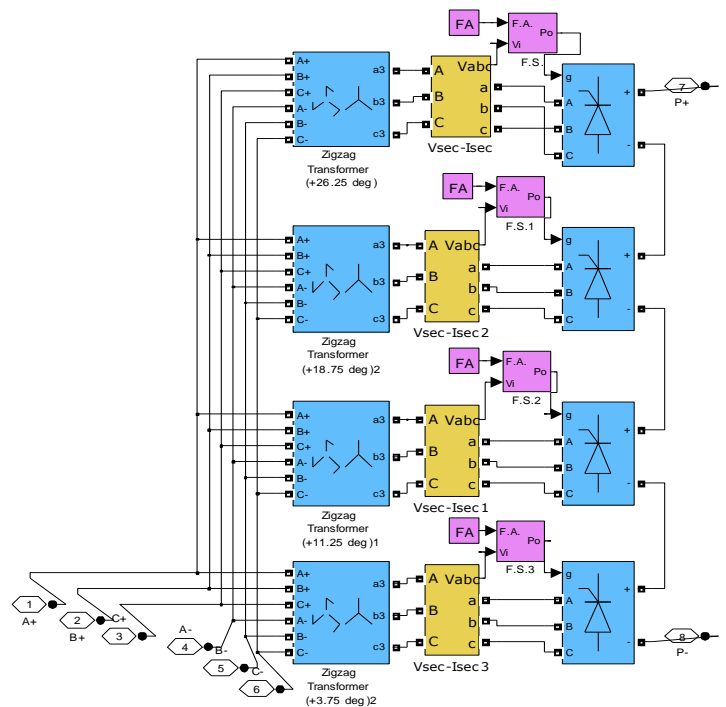

Fig. 8 Thirty six pulse controlled converters with resistive load

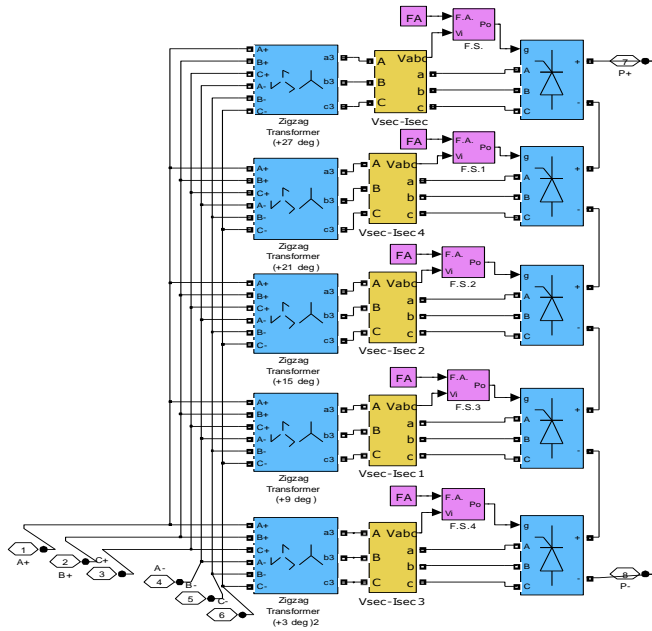

Fig. 9 Thirty six pulse controlled converters with resistive load

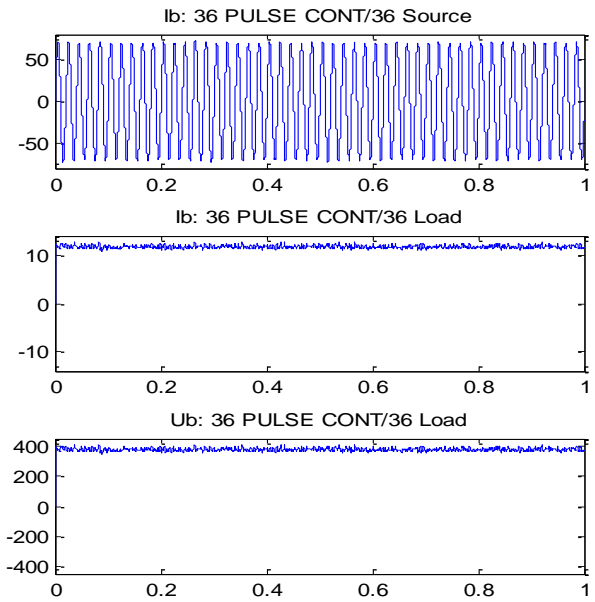
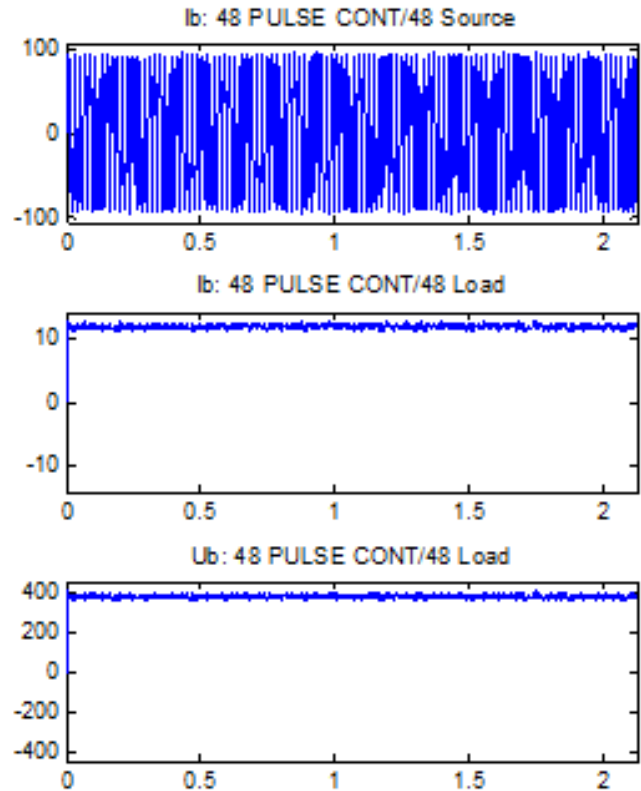
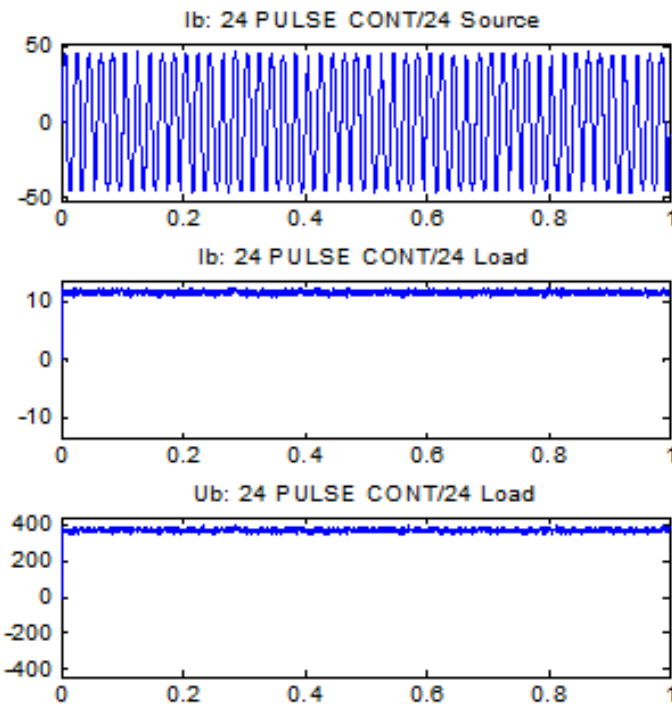

Fig.10. Ripple factor, form factor and mean value of voltage respectively of 24 and 36 pulse generator

## 5. Results and Discussion





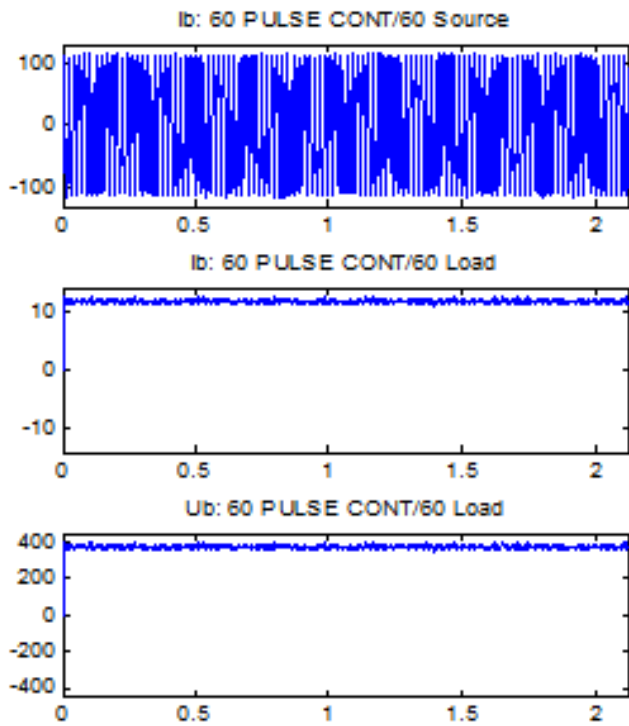

Fig.11.Ripple factor, form factor and mean value of voltage respectively of 48 and 60 pulse generator

Table 1 Comparative result of the converters

Converter pulses	Ripple %	Form Factor	THD
24	1.384	1	4.43
36	0.7016	1	1.90
48	0.7153	1	1.98
60	0.7329	1	1.16

## 6. CONCLUSION

An analysis of simulation results was performed and the following conclusions can be drawn without loss of generality. Increasing the number of converter pulses reduces the voltage ripples. Form factor is also improves though insignificantly. The harmonics in the supply system are almost

eliminated. The voltage ripples increase as the firing angle is increased.

## References

- [1].Wen Jiaopu; Haihong Qin; Shishan Wang; Bo Zhou, "Basic connections and strategies of isolated phase-shifting transformers for multipulse rectifiers: A review", Asia-Pacific Symposium on Electromagnetic Compatibility (APEMC), pp 105-108, 2012.
- [2].R Maurya, P Agarwal, S.P Srivastava, "Performance investigation of Multipulse Converter for Low Voltage High Current applications", IEEE International Conference on Computer Science and Automation Engineering (CSAE), pp-211-216, 2011.
- [3].P.K Singh, Y.K Chauhan, "Performance analysis of multi-pulse electronic load controllers for self-excited induction generator", International Conference on Energy Efficient Technologies for Sustainability (ICEETS), pp-1299-1307, 2013.
- [4].A Chaturvedi, D Masand, Gupta, S. Tiwari, S. Jain, M., "Comparative analysis of three phase AC-DC controlled multi pulse converter", IEEE Students' Conference on Electrical, Electronics and Computer Science (SCEECS), pp 1-4, 2012.
- [5].Valderra, bano, A. Ramirez, J.M. Correa, R.E., "A new 84-pulse VSC configuration using multi-level DC voltage reinjection for especial applications", IEEE International Conference on

- Industrial Technology (ICIT), pp.1715-1720, 2010.
- [6].Xigeng Ma; Chao Li, Lina Bai, Ying Liu, “Analysis and Mat lab Simulation of 30-Pulse Rectification System Based on Stretch Triangle Transformer”, International Conference on Electrical and Control Engineering (ICECE), pp 3312-3315, 2010.
- [7].A N Arvindan, A. Guha, “Novel topologies of 24-pulse rectifier with conventional transformers for phase shifting”, 1st International Conference on Electrical Energy Systems (ICEES), pp 108-114, 2011.
- [8].I. Sefa, Altin, N. Colak, I. zdemir, S., “18 pulse controlled rectifier: A case study on UPS”, 13th European Conference on Power Electronics and Applications, pp 1-9, 2009.
- [9].Singh, B.; Garg, V. Bhuvaneswari, G. , Design and Development of Autotransformer Based 24-Pulse AC-DC Converter fed Induction Motor Drive, 7th International Conference on Power Electronics and Drive Systems, 2007.
- [10]. Sahoo, AK. Murugesan, K. Thygarajan, T., Modeling and simulation of 48- pulse VSC based STATCOM using simulinka power system block set, International Conference on Power Electronics, 2006. IICPE, India, pp. 303-308, 2006.